

Assembly Instructions for cable gland: 501/421

Operating temperature range -60°C +100°C

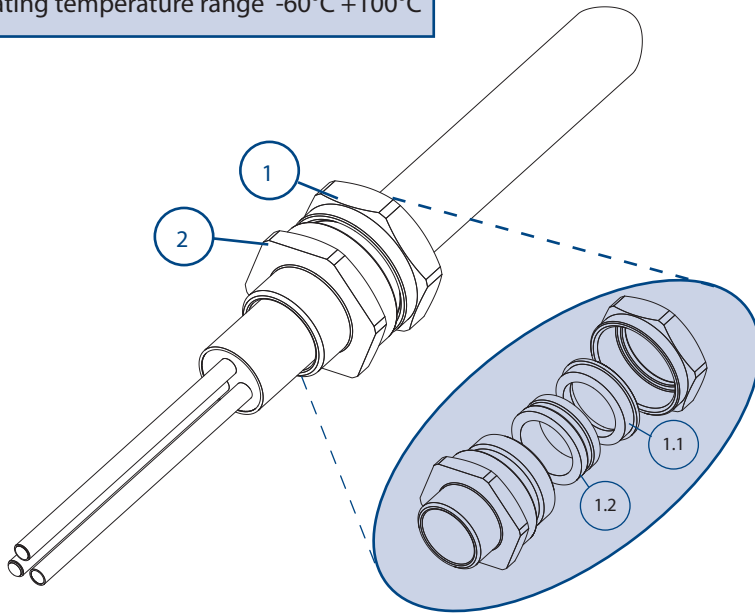

Certification Details

Gland Type: 501/421
 Exdb IIC Gb, Exeb II Gb, Extb IIIC Db
 CML19ATEX1167X Ex II 2 GD IP66/67 CE
 IECEx CML19.0045X
 IEx 14.0272X
 EAC Pending
 c CSA us No: 1015065
 Class 1 Zone 1 AExd IIC, AExe II, Zone 21 AExtD
 Class 1 Div 2 ABCD, Class II Div2 Groups EFG, Class III

- 1. Backnut
- 1.1 Compression Spigot
- 1.2 Seal
- 2. Entry

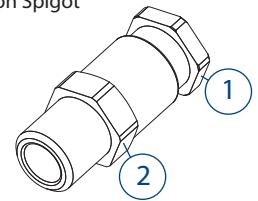

421/2K size only.
 View for clarity only,
 do not disassemble ① & ②.

Cable Preparation

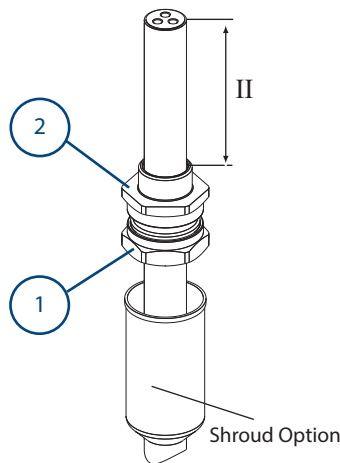

A
 Allow sufficient length of cable, II, to suit equipment.
 If required, fit shroud.
 Pass cable through the cable gland as shown above.

Note: If the equipment has a threaded entry, it may be advisable to screw the cable gland into the equipment to prevent twisting of the cable after Step B

Gland Preparation

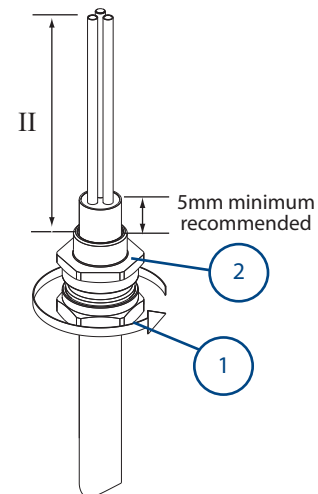

B
 Unless already screwed into the equipment, hold the entry ② in position with a spanner/wrench to prevent rotation and tighten the backnut ① using a wrench/spanner until resistance is felt between the seal and cable. Then turn the back nut through a further half to one full turn to complete the inner seal. Locate the shroud over the cable gland, if applicable.

To ease wiring inside the equipment it may be beneficial to strip the outer sheath of the cable as shown above.

IMPORTANT: Support the cable to prevent it from twisting

CABLE GLAND SELECTION TABLE										
Size Ref.	Entry Thread Size		Cable Acceptance Details				Compressed Length	Maximum Length	Hexagon Dimensions	
			Outer Sheath							
	Metric	NPT	Standard Seal		Alternative Seal (S)					
			Min.	Max.	Min.	Max.			Across Flats	Across Corners
2K	M16	---	3.2	8.0	---	---	23.5	39	19.0	21.2
Os	M20 [•]	½"	3.2	8.0	---	---	23.8	38	24.0	26.5
O	M20 [•]	½"	6.5	11.9	---	---	23.8	39	24.0	26.5
A	M20	½" - ¾"	10.0	14.3	9.0	13.4	24.8	38	30.0	32.5
B	M25	¾" - 1"	13.0	20.2	9.5	15.4	25.8	41	36.0	39.5
C	M32	1" - 1¼"	19.5	26.5	15.5	21.2	28.2	43	46.0	50.5
C2	M40	1¼" - 1½"	25.0	32.5	22.0	28.0	29.5	44	55.0	60.6
D	M50	1½" - 2"	31.5	42.3/44.4	27.5	34.8	40.4	61	65.0	70.8
E	M63	2" - 2½"	42.5	54.3/56.3	39.0	46.5	38.2	59	80.0	88.0
F	M75	2½" - 3"	54.5	65.3/68.2	49.5	58.3	40.5	60	95.0	104.0
G	M80	3½"	67.0	73.0	---	---	41.0	54	106.4	115.0
H	M90	3½"	67.0	77.6	---	---	41.0	54	115.0	130.0
J	M100	4"	75.0	91.6	---	---	41.0	54	127.0	142.0

- Sizes Os and O are available with an M16 thread size. If M16 entry is used on O size Cable Glands the maximum cable inner sheath diameter is limited to 10.9mm.

IMPORTANT NOTE:

When used in Increased Safety applications, these cable glands may be used with braided cables where the braid and the outer sheath pass into the enclosure. The braid must then be suitably terminated within the enclosure. Braided cable is classed as unarmoured cable in the EN/IEC 60079 series standards for Exe applications.

SCHEDULE OF LIMITATIONS - ATEX / IECEx:

1. The cable glands are only suitable for use with fixed apparatus, the cable for which must be effectively clamped and cleated elsewhere.
2. This cable gland has an operating temperature range of -60°C to +100°C.
3. A seal must be formed between the equipment and the cable gland to maintain the appropriate degree of protection against ingress of dust, solid objects and water.

TORQUE VALUES

All torque values below were generated on metallic mandrels. For cable, it is recommended that the assembly instructions are followed.

Torque Figures N/m									
Gland Size	Os	O	A	B	C	C2	D	E	F
BacknutTorque	30	30	32.5	47.5	55	65	82.5	97.5	115

NOTES - c CSA us:

1. The cable used must have extruded sealing (solid polymeric) completely surrounding the "core" (insulation and conductor), allowing for no holes or ventilation through the inner jacket or along the cores.
2. The 501/4** series cable gland connectors, when used in Class 1 Division 2 Classified areas, are not suitable to be interfaced with an explosion proof enclosure containing arcing and sparking devices, unless installed in conjunction with an approved explosion proof sealing fitting.
3. These glands are suitable for use with Certified Marine Shipboard armoured / unarmoured cables constructed to CSA Standard 245 and IEEE45 / IEC 600092-353 Standards, or certified equivalent), for use on Shipboards and Offshore Rigs / Platforms.
4. Must comply with Canadian Electrical Code and National Electric Code requirements for threaded entries.
5. For Exe applications, a sealing washer or thread sealant may be required between the enclosure and the gland to maintain the IP rating of the enclosure.
6. When used with unarmoured or braided cables the glands are only suitable for use with fixed apparatus and the cable must be effectively clamped and cleated elsewhere.
7. This cable gland may only be installed when temperature is above -5°C. After completion of the installation, the assembly is then suitable for -60°C to +100°C.

EU Declaration of Conformity in accordance with European Directive 2014/34/EU

Manufacturer: Hawke International

Address: Oxford Street West, Ashton-under-Lyne, OL7 0NA, United Kingdom.

Equipment: Group II Compression Cable Glands Type: 501/421

Provisions of the Directive fulfilled by the Equipment: Group II Category 2GD Exeb IIC Gb, Exdb IIC Gb, Extb IIIC Db – IP66/67

Notified Body for EU-Type Examination: CML 2776 Chester UK

EU-type Examination Certificate: CML19ATEX1167X

Notified Body for production: SGS-Baseefa 1180 Buxton UK

Harmonised Standards used: EN 60079-0:2018, EN60079-1:2014, EN60079-7:2015, EN60079-31:2014

On behalf of the above named company, I declare that, on the date the equipment accompanied by this declaration is placed on the market, the equipment conforms with all technical and regulatory requirements of the above listed directives.



A. Tindall
Technical Manager